



epeco.usa



EP.MEDI

Medical Waste
Thermal Incinerators

up to 200 kg/hr

Medical Waste Incineration..... why?



Lack of Central Hazardous Waste Reception Facilities are is not a problem.

No costs for discharging Medical Waste Garbage.



Incineration at high temperatures is an eco-friendly process, giving the "Clean Environment" notation.

EP.MEDI..... Soution...



EP.MEDI, the Medical Waste Incinerators are designed to burn Type IV of pathological waste and infectious, contaminated “red bags”, surgical dressings, plastic test devices, materials used to prepare anti-cancer chemotherapy, out of date drugs, anatomic parts, liquid waste body fluids (blood, etc.) and similar wastes.

EP.MEDI series.....

- Operated with minimum skills.
- Requires minimum operational training.
- Friendly user maintenance protocols.
- Complies with US and European emission standards.
- Operates for full day time (with automatic loader and de-ashing).
- Optional gas scrubbing.
- Utilizes multiple fuel supply-diesel oil and/or hydrocarbon gases.
- Capable for efficient waste incineration including hazardous medical wastes, food, plastics, oils, wood, paper ...and more.
- Can be delivered in standard ISO containers or in special frame.
- Warranted for one year against components and material failure.
- Performance guaranteed for three years against mal-functioning.



EP.MEDI..... System..



- 1 waste loading front gate
- 2 primary combustor
- 3 primary waste de-ashing
- 4 primary burner
- 5 secondary burner

- 6 secondary combustor
- 7 secondary de-ashing
- 8 chimney
- 9 chimney de-ashing gate
- 10 quenching tower
- 11 wet scrubber tower

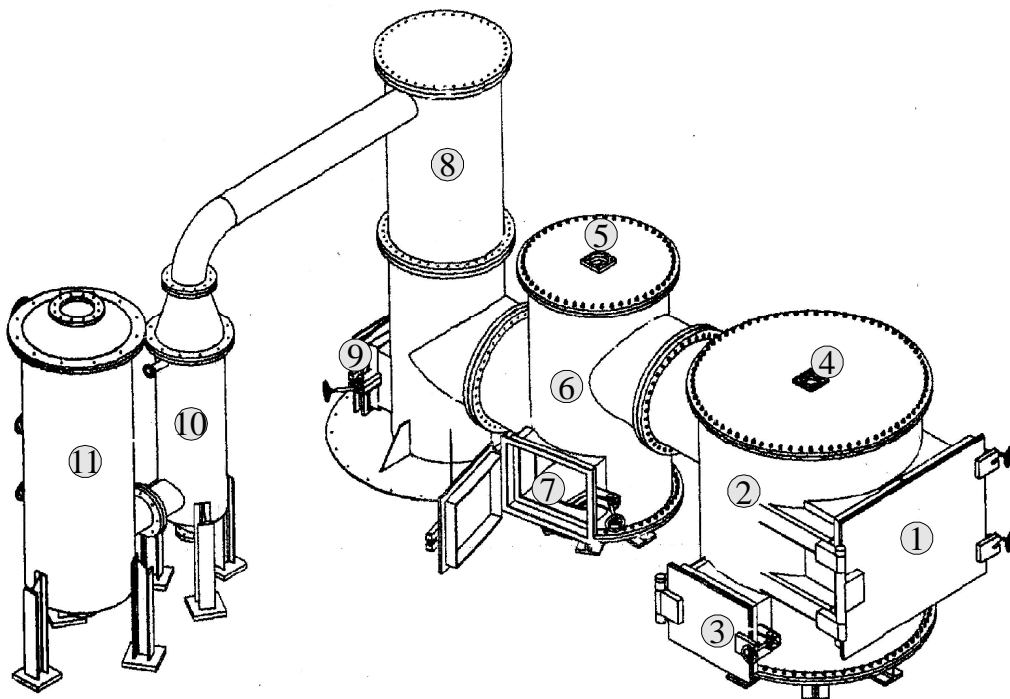

The EP.MEDI systems are designed in two stage incineration process, comprising a primary combustor for the total destruction of the solid/liquid wastes. The secondary combustor/after burner which draws the hot gases from the primary chamber and superheats it to approximately 1100-1300 °C for 2 seconds as a minimum. This ensures nearly full destruction/thermal decomposition of the exhaust gas.



Secondary
Combustor/
After Burner

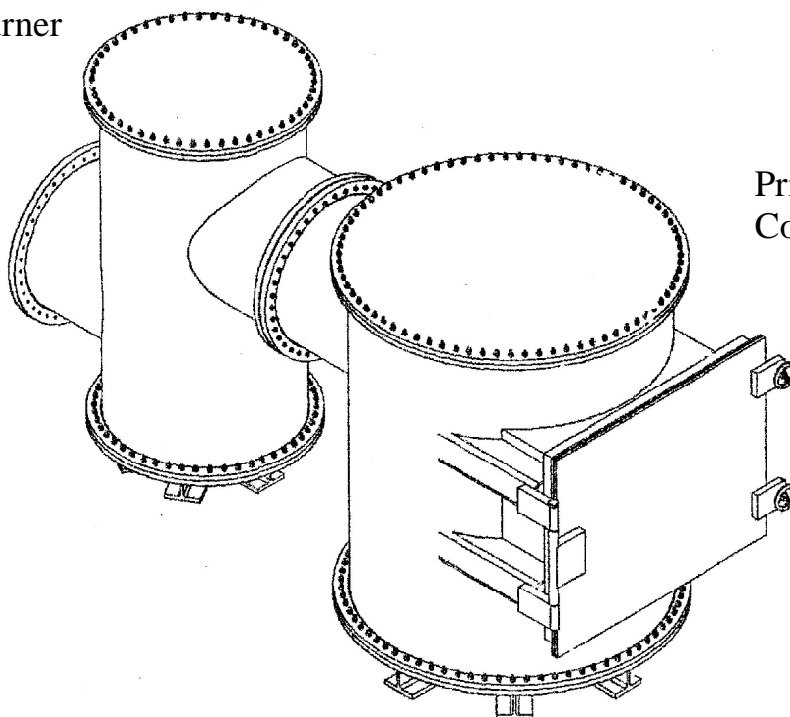

Primary
Combustor

The outer shell of the EP.MEDI system is manufactured from 8 & 10 mm robust mild steel sheets, seam welded & structured to provide stiff body. The steel body of the EP.MEDI system is coated with two packs high grade paint system that is baked onto the steel structure at 70°C for 10 hrs. Standard colors of the EP.MEDI systems are cherry red for the main body, with a solid black gates and upper cover plates.

A combined insulation is consisting of one layer of refractory castable stone lining and light weight calcium silicate outer insulation will protect the outer steel shell and will keep its temperature less than 55°C. All gates and chimney base are insulated in the same way.

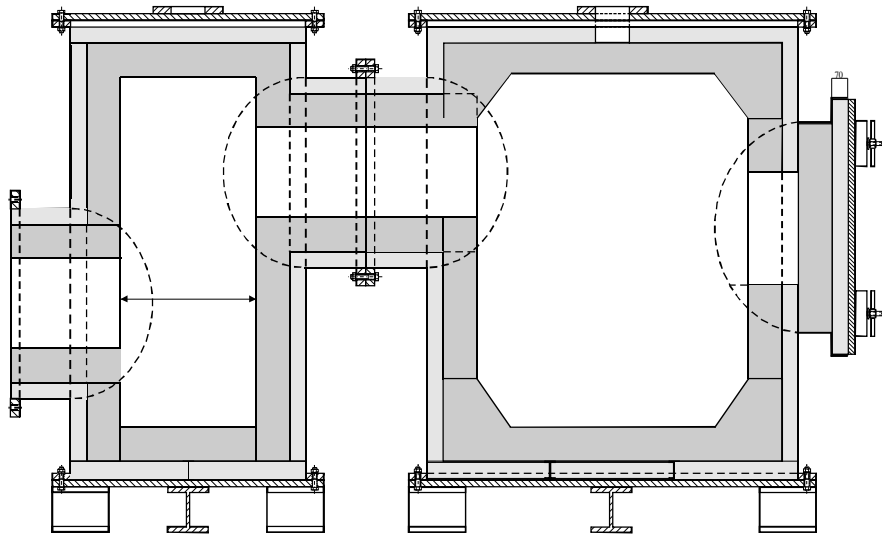

The primary combustor is fitted with one temperature/timer controlled burner allowing for temperature rise up to 900°C. The secondary combustor is fitted with a temperature controlled burners as well, which fires automatically when the secondary combustor temperature is below 1100°C. Burners are Natural Gas, and/or Diesel Fuel Fired.

Auxiliary air for the primary combustor is provided by direct drive centrifugal fans and injected in an air curtain surrounding the flame. Air is also injected at the stack bottom for drifting the exhaust gases through-out the stack or the next gas scrubber.

EP.MEDI systems are delivered with standard 6 meters round steel stack, fully insulated as well as the primary and secondary combustors.

Air blowers, control panel, water supply pumps (optional) and fuel tank are skid mounted and delivered to site ready for hook up to the EP.MEDI system.

The primary combustor is fitted with one temperature/timer controlled burner allowing for temperature rise up to 900°C. The secondary combustor is fitted with a temperature controlled burners as well, which fires automatically when the secondary combustor temperature is below 1100°C. Burners are Natural Gas, and/or Diesel Fuel Fired.

Auxiliary air for the primary combustor is provided by direct drive centrifugal fans and injected in an air curtain surrounding the flame. Air is also injected at the stack bottom for drifting the exhaust gases through-out the stack or the next gas scrubber.

EP.MEDI systems are delivered with standard 6 meters round steel stack, fully insulated as well as the primary and secondary combustors.

Air blowers, control panel, water supply pumps (optional) and fuel tank are skid mounted and delivered to site ready for hook up to the EP.MEDI system.

EP.MEDI.....Performance

EP.MEDI systems can incinerate the specified medical or bio hazard wastes and will reduce it to nearly 3% of its original volume and to about 12% of its original weight.

EP.MEDI systems can incinerate medical or bio hazard wastes of category 1,2,3 & 4 red bags (blood drips, human ,organs, tissues, limbs, cancer treatments, pharmaceutical, surgery wastes and siring needles). EP.MEDI systems can also incinerate cremation of animal carcasses such as dogs, cats, mice, poultry,...etc.

EP.MEDI systems are thermally efficient as special refractory lining is implemented in the primary & secondary chambers and the chimney base. Efficiency is maximized when auto waste loading and de-ashing (optional) is fit to the EP.MEDI system as no need to cool down the incinerator prior to re-loading and/or de-ashing.

As a result of the powerful heat sources and the unique combustion chambers design, EP.MEDI systems can handle hazardous wastes with moisture content up to 50%.

By implementing the two stage incineration process; primary and secondary combustors, various process stages (waste burning and flue gases superheating) evolve separately, both in time and with regard to location. This will allow for process optimization resulting in high thermal efficiency, full waste incineration and full thermal decomposition of the flue gases. Noxious solid state disposal, smoke free and partially clean exhaust gases will be guaranteed.

High temperature (up to 1300 °C) and long residence time (more than 2 m/sec) in the secondary combustor guarantee an ideal incineration end products . The combustion is free of soot. Exhaust gases will comply with the EN 746-2:2010 or better.

EP.MEDI systems are designed to operate in plug & play mode. Minimum operator's attendance is required. This approach is allowing for easy and efficient operation & maintenance. Waste feed and de-ashing cycle can be programed (optionally) for maximum loading rate and minimal operators interference. With optional Process Logic control PLC, of EP.MEDI remote process control can be achieved.

EP.MEDI.... Manufacturing?



EP.MEDI are manufactured by the Arabian Organization for Industrialization, Cairo/Egypt.



EP.MEDI..... Technical Data

	EP.MEDI 50	EP.MEDI 100	EP.MEDI 150	EP.MEDI 200
Feed Capacity, Kg/hr	50	100	150	200
Feed Volume, m ³ /hr	0.5	1	1.5	2
Specific Calorific Value of Waste Kw/Kg Kcal/Hr/Kg (Kcal/Hr/Kg)	4 (3442)			
Thermal Power, Kw	240	320	600	800
Burner Power Kw				
Primary	250	280	310	320
Secondary	250	280	310	320
Temperature °C				
Primary		800-900		
Secondary		1100-1300		
Electric Power Supply, Kw	3	4	6	6

EP.MEDI..... Dimensions & Weights

	EP.MEDI 50	EP.MEDI 100	EP.MEDI 150	EP.MEDI 200
Dimension (external), Combustors				
Height x Dia. mm				
Primary	2000 x 1290	2000 x 1840	2000 x 1940	2000 x 2140
Secondary	2000 x 940	2000 x 1040	2000 x 1440	2000 x 1640
Combustor Volume m ³				
Primary	0.8	1.8	2.7	3.6
Secondary	0.3	0.6	0.8	1.5
Dimensions, Chimney				
Height x Dia. mm	6 x 0.3	6 x 0.35	6 x 0.4	6 x 0.5
Dimensions Feed Gate				
Width x Height mm	700 x 450	800 x 500	800 x 500	800 x 600
Dimensions Ash Disposal Gates				
Width x Height mm				
Primary	300 x 300	400 x 300	400 x 300	400 x 300
Secondary	250 x 250	300 x 250	300 x 250	300 x 250
Chimney	200 x 200	200 x 200	200 x 200	200 x 200
Weight (excl Chimney) kg	6'000	9'000	11'000	12'500

EP.MEDI..... Options

Auto Feeder

EP.MEDI systems are basically designed for manual batch feeding. Optional automatic feeding is available as well. Automatic Feeder is utilizing pneumatic cylinders to open and close the incinerator main gate. Pneumatic Actuator is also implemented to push the load into the primary combustor. The gate & the actuators motion is synchronized in linear motion process.

Auto De-ashing

EP.MEDI is designed for manual de-ashing operation. EP.MEDI can be fit with vacuum de-ashing, Manual vacuum control is standard, while automatic sequence control is also available.

Chimney

EP.MEDI systems can be supplied with Chimneys with total dimensions according to the local regulations. EP.MEDI standard Chimneys comes in 6 meters high segments and made from stainless steel 304 L. Optional internally enamled mild steel Chimneys are also available. In all cases, the Chimney base is made of mild steel internally lined with refractory stones.

Wet Scrubbers

An Auxiliary Wet Scrubber can be attached to the EP.MEDI systems to further clean the exhaust gases. The wet scrubbers comprise a quenching tower, where water spray is injected in the flue gases stream. Cooled wet flue gases are forced upward with water spray is injected downward. Gases are allowed to dissolve in the water spray and clean air is excused, Acidic water is reconditioned/pH adjusted, filtered and cooled prior to recycling through the quenching tower.

Dry Scrubbers

Dry Scrubbers are a catalytic converter which absorbs the exhaust emission and convert toxic gases and pollutants in exhaust gas stream to less toxic pollutants by catalyzing a redox reaction. Dry Scrubbers is useful in places where water supply is limited.

PLC control

EP.MEDI is designed to work on Batch Operation Mode BOM. In BOM the batch is manually charged then the combustion of the whole waste material is automatic and does not require any further operator attendance. The variables such as temperature and time are either manually or automatically controlled. In automatic control, Process Logic Control PLC can be implemented to collect control data, analyze them, and take actions according to a preset program.



epeco.usa

Middle East & North Africa Div.

P.O.Box 8052 Cairo 11371
10, Tayaran Str., Raba'a al Adawia
Nasr City 11371, Cairo, EGYPT
pH: +20 2 240 6626 cell: +20 12 2210 4150
e.mail: info@epecousa.com www.epecousa.com